

A stylized world map in light gray is centered in the background. The right side of the image features a solid blue vertical band. The word "Looking" is written in a large, bold, blue font with a white outline, positioned on the left side of the map.

Looking

for filtration

Expanded mesh filter

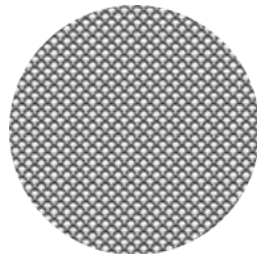

COPOR

## Filtri da tele

Copor, azienda leader nella produzione di sistemi filtranti, produce filtri a rete mediante punzonatura e saldatura di una grande varietà di reti metalliche e reti stirate per soddisfare ogni specifica del cliente.

La maglia è ottenuta tessendo fili continui su telai meccanici automatici. Si forma così un telo reticolare, composto da Fili di Trama che definiscono la larghezza del telo, e Fili di Ordito che ne definiscono la lunghezza. I filtri in rete e tela metallica possono essere realizzati in tutti i metalli e le leghe trafilabili. Tra quelli più utilizzati, Copor realizza filtri a tela in acciaio inox AISI 304L, bronzo, ottone, ferro e ferro zincato.

Il diametro del filo dei filtri a rete Copor va da 0,04 a 2 mm e il grado di filtrazione da 10 a 150 micron per i filtri a rete, da 300 a 2000 micron per la rete stirata.

Il loro utilizzo spazia dall'industria chimica, alimentare, farmaceutica e automobilistica.

La robustezza e la resistenza alle alte temperature rendono gli elementi filtranti a rete ottimali in molteplici ambiti: dalla filtrazione di gas e carburanti nel settore automotive, alle depurazioni e filtrazioni nell'industria chimica di processo. Nella comune filtrazione alimentare anche a livello domestico fino ad impieghi nella disinfezione e depurazione in campo farmaceutico.

I filtri a rete possono essere realizzati anche con materiali speciali particolarmente resistenti. Questo li rende ottimi strumenti anche per filtrare sostanze aggressive.

Copor produce filtri a rete in un'ampia gamma di forme e dimensioni ea diversi livelli di porosità secondo il disegno e le esigenze del cliente. Disponiamo inoltre di una vasta gamma standard di dischi semplici e di forma cilindrica, realizzati con lamiere microstirate, prego consultare le seguenti pagine.

## Mesh filters

Copor, a leading company in the production of filtering systems, produces mesh filters by punching and welding a large variety of wire mesh and expanded mesh in order to satisfy every customer specification.

The mesh is obtained by weaving continuous wires on automatic mechanical looms. Thus a reticular cloth is formed, composed of Weft threads which define the width of the cloth, and Warp threads which define its length.

Mesh and wire cloth filters can be made in all drawable metals and alloys. Among those most commonly used, Copor manufactures cloth filters in AISI 304L stainless steel, bronze, brass, iron and galvanized iron.

The wire diameter of Copor mesh filters ranges from 0.04 to 2 mm and the degree of filtration from 10 to 150 microns for mesh filters, from 300 to 2000 microns for expanded mesh.

Their use ranges from the chemical, food, pharmaceutical and automotive industries.

The robustness and resistance to high temperatures make the element mesh filters optimal in many areas: from the filtration of gases and fuels in the automotive sector, to the purifications and filtrations in the chemical process industry. In common food filtration even at a domestic level up to uses in disinfection and purification in the pharmaceutical field.

Mesh filters can also be made with particularly resistant special materials. This makes them excellent tools even for filtering aggressive substances.

Copor manufactures mesh filters in a wide range of shapes and sizes and at different levels of porosity according to the customer's design and needs.

We also have a wide standard range of simple discs and cylinders shape, manufactured with expanded mesh, please see in the next pages.

## Caratteristiche

Lamiera/tessuto

## Characteristics

sheet/fabric

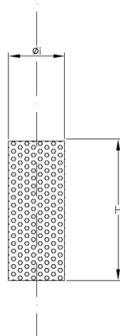

## Caratteristiche

Lamiera/tessuto

## Characteristics

sheet/fabric

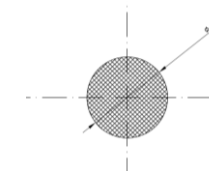
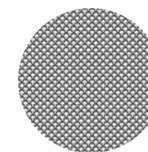

**FILTRI IN TELA**  
Lamiera microstirata  
MESH FILTER  
Expanded mesh

### modello CILINDRO/CYLINDRIC

TYPE	Øi mm	H
ME6,6	6,6	8,6
ME7,4X10,5	7,4	10,5
ME7,5-12/1	7,5	12
ME8-22	8	22
ME8,6-0,85INV	8,1	7
ME8,3X22	8,3	22
ME8,5X22	8,5	22
ME9-12/0,85	9	12
ME9-5	9	5
ME9	9,85	17
ME10,4X13	9,9	13
ME10,1X11,6	10,1	11,6
ME10,6-0,75	10,6	12,5
ME12X10,5	12	10,5

TYPE	Øi mm	H
ME12,5	12,5	10,5
ME14	14	8
ME14,3-8,2	14,3	8,2
ME15	15	11,5
ME15X5,5	15	5,5
ME16X29,5	15,4	29,5
ME17X9,5	17	9,5
ME17,6X9	17,6	9
ME19,5X127	19,5	127
ME20-50	20	50
ME23	23	22
ME27-145 100M	27	145
ME100X600	100	600

### modello DISCO/FLAT

TYPE	Ø mm
ME4	4
ME5	5
ME5,9	5,9
ME6	6
ME6,5	6,5
ME7-0,25	7
ME8	8

TYPE	Ø mm
ME12,8	12,8
ME13	13
ME14,5-0,75	14,5
ME17-0,45	17
ME18	18
ME18,5	18,5
ME19	19
ME20	20

TYPE	Ø mm
ME8,5	8,5
ME9-1	9
ME10-0,20	10
ME10	10,25
ME11	11
ME11,5	11,5
ME11,8	12

TYPE	Ø mm
ME22	22
ME34,6	34,6
ME50,5	50,5
ME55	55
ME60	60
ME158	158
ME22	22

# LAMIERE MICROSTIRATE

EXPANDED MESH

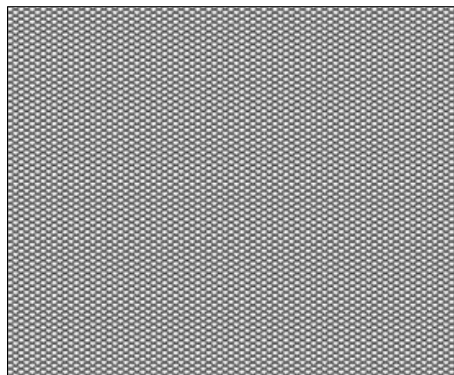

MF 0,50

TIPO RETE : M.F. 0,50  
MATERIALE : Acciaio inox AISI 304  
TIPO DI FORO : Romboideale  
DIMENSIONI FORO : DL. 0,50 mm  
DC. 0,40 mm  
LAMIERA : AV. 0,16 mm  
SP. 0,08 mm (spessore)

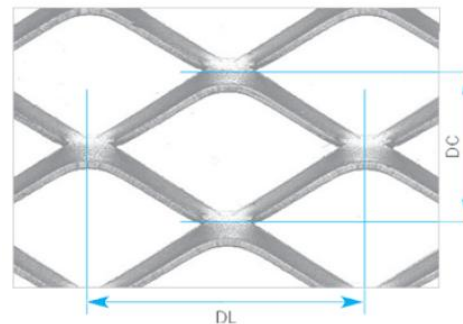

## Legenda

**R** = Passo = DL  
**DL** = Diagonale lunga  
**DC** = Diagonale corta  
**av** = Avanzamento  
**sp** = Spessore

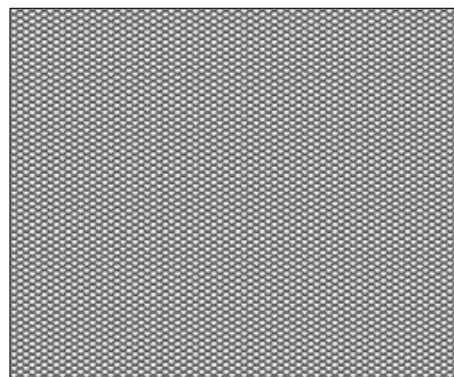
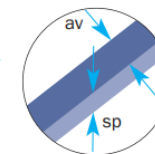

MF 0,75

TIPO RETE : M.F. 0,75  
MATERIALE : Acciaio inox AISI 304  
TIPO DI FORO : Romboideale  
DIMENSIONI FORO : DL. 0,75 mm  
DC. 0,60 mm  
DIMENSIONI FILO : AV. 0,20 mm  
SP. 0,15 mm (spessore)

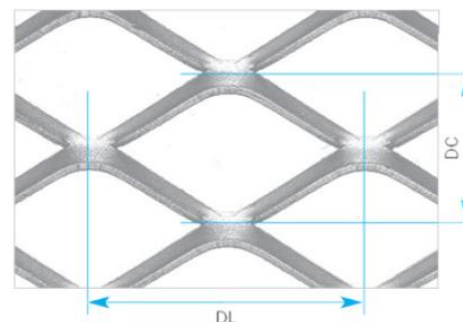

## Legenda

**R** = Passo = DL  
**DL** = Diagonale lunga  
**DC** = Diagonale corta  
**av** = Avanzamento  
**sp** = Spessore

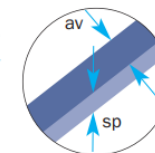

# LAMIERE MICROSTIRATE

EXPANDED MESH

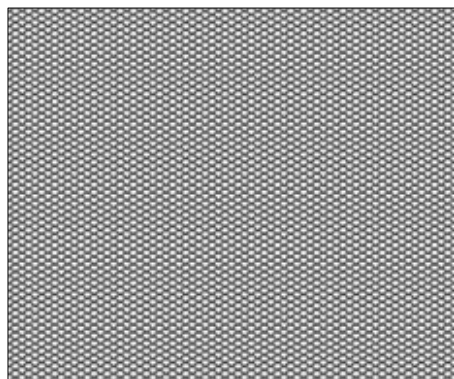

MF 0,85

**TIPO RETE :** M.F. 0,85  
**MATERIALE :** Acciaio inox AISI 304  
**TIPO DI FORO :** Romboideale  
**DIMENSIONI FORO :** DL. 0,85 mm  
DC. 0,60 mm  
**DIMENSIONI FILO :** AV. 0,23 mm  
SP. 0,15 mm (spessore)

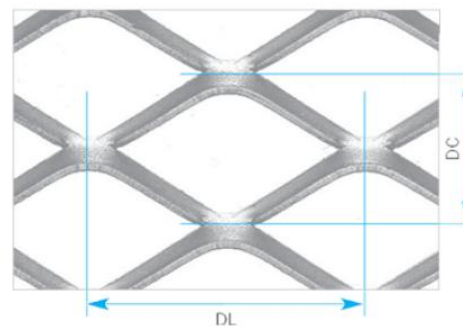

## Legenda

**R** = Passo = DL  
**DL** = Diagonale lunga  
**DC** = Diagonale corta  
**av** = Avanzamento  
**sp** = Spessore

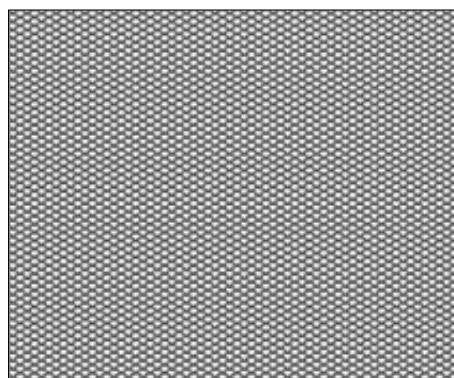
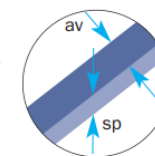

MF 1

**TIPO RETE :** M.F. 1  
**MATERIALE :** Acciaio inox AISI 304  
**TIPO DI FORO :** Romboideale  
**DIMENSIONI FORO :** DL. 1 mm  
DC. 0,75 mm  
**DIMENSIONI FILO :** AV. 0,25 mm  
SP. 0,15 mm (spessore)

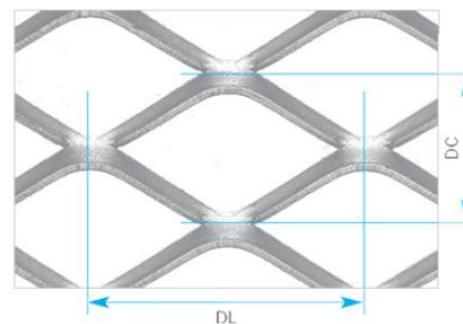

## Legenda

**R** = Passo = DL  
**DL** = Diagonale lunga  
**DC** = Diagonale corta  
**av** = Avanzamento  
**sp** = Spessore

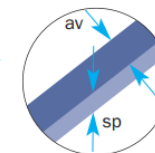

# LAMIERE MICROSTIRATE

EXPANDED MESH

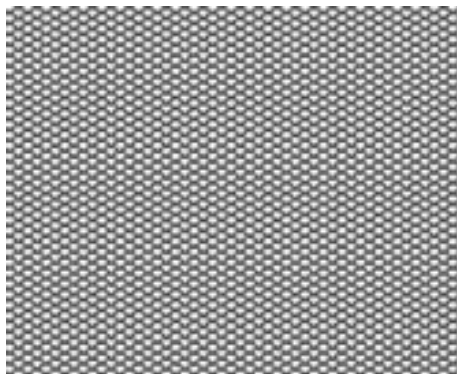

MF 1,5

**TIPO RETE :** M.F. 1,5  
**MATERIALE :** Acciaio inox AISI 304  
**TIPO DI FORO :** Romboideale  
**DIMENSIONI FORO :** DL. 1,5 mm  
DC. 0,9 mm  
**DIMENSIONI FILO :** AV. 0,20 mm  
SP. 0,15 mm (spessore)

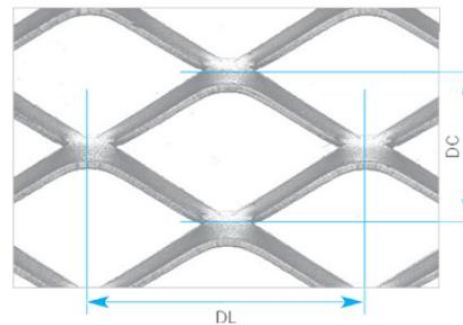

## Legenda

**R** = Passo = DL  
**DL** = Diagonale lunga  
**DC** = Diagonale corta  
**av** = Avanzamento  
**sp** = Spessore

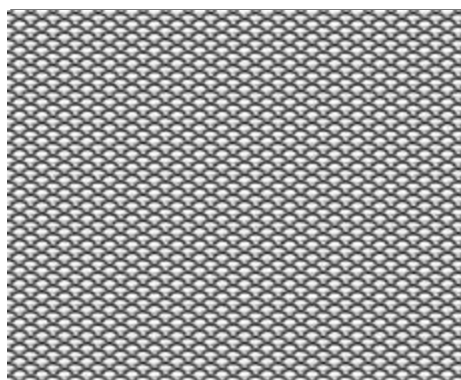
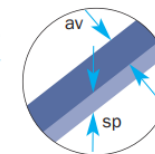

MF 2

**TIPO RETE :** M.F. 2  
**MATERIALE :** Acciaio inox AISI 304  
**TIPO DI FORO :** Romboideale  
**DIMENSIONI FORO :** DL. 2 mm  
DC. 1,3 mm  
**DIMENSIONI FILO :** AV. 0,35 mm  
SP. 0,25 mm (spessore)

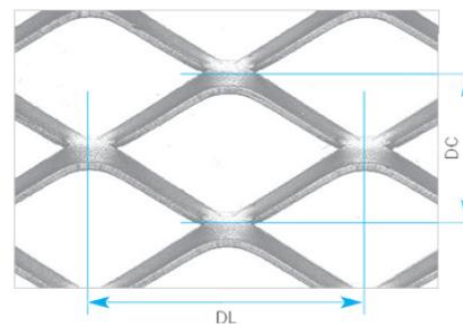

## Legenda

**R** = Passo = DL  
**DL** = Diagonale lunga  
**DC** = Diagonale corta  
**av** = Avanzamento  
**sp** = Spessore

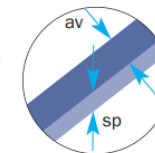

# ALTRI PRODOTTI

OTHER PRODUCTS

## FILTRI INOX STAINLESS POWDER FILTERS



## FILTRI IN BRONZO BRONZE FILTER



## FILTRI DA TELA WIRE FILTERS



